

38" VAULT RISER

AVAILABLE IN: 4", 6" & 12" HEIGHTS

(3) STANDARD LIFTING HANDLES ON 12"

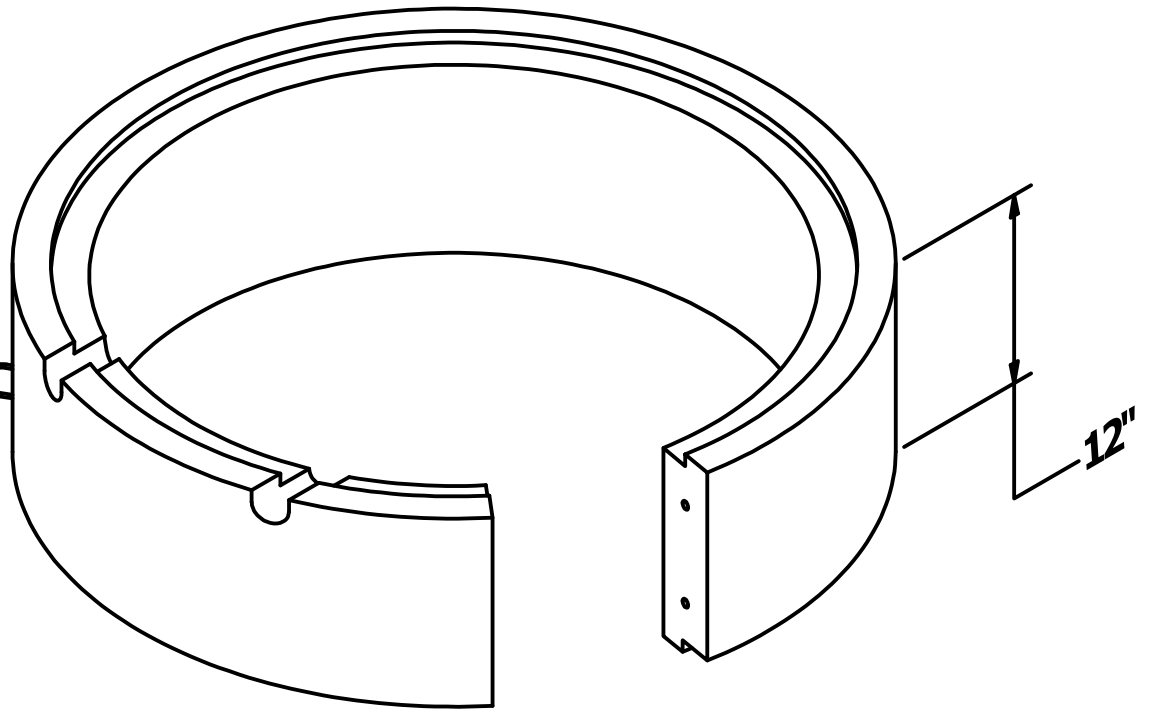

(3) STANDARD LIFTING HANDLES ON 6"

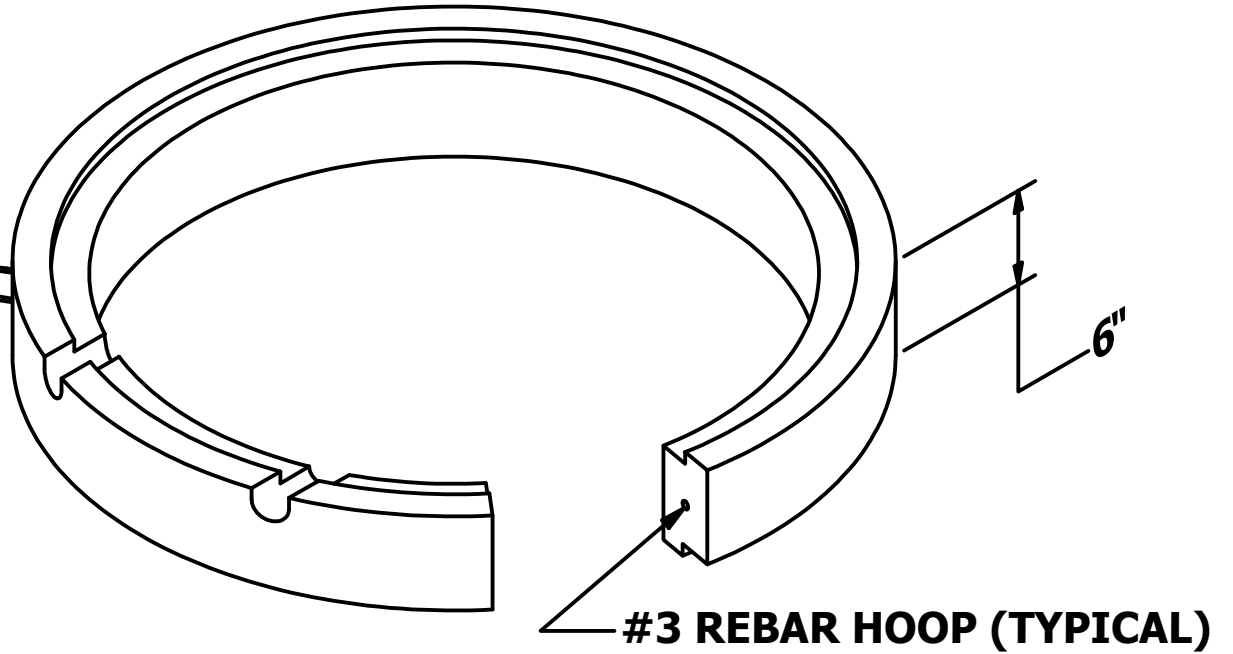

(3) STANDARD LIFTING HANDLES ON 4"

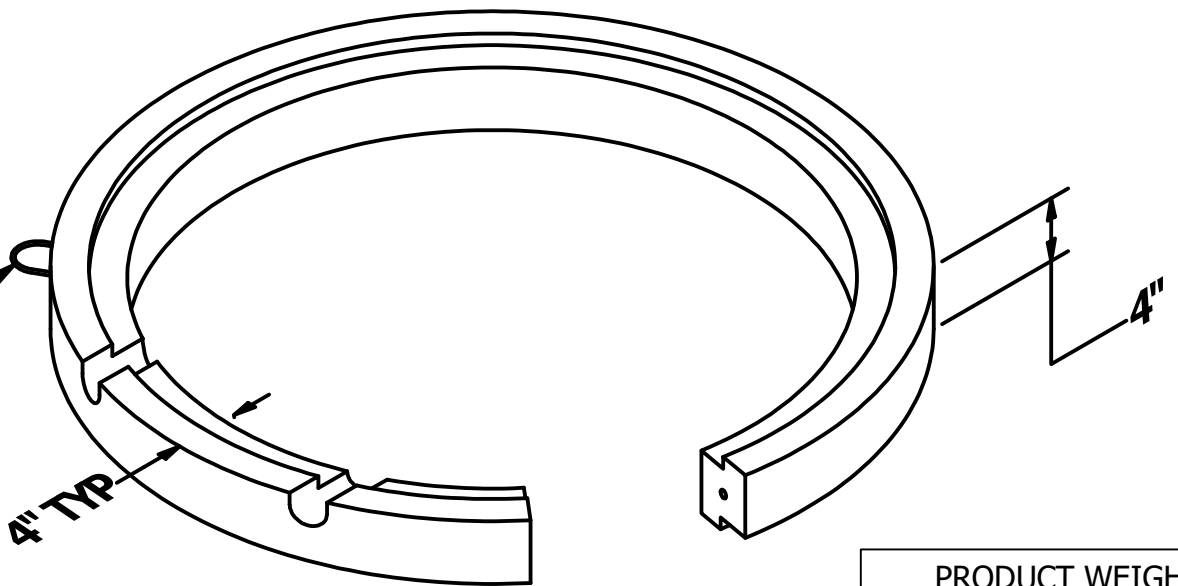

PRODUCT WEIGHTS	
RING HEIGHT	GRADE RING
4"	182 LBS
6"	274 LBS
12"	550 LBS



Precast Concrete, LLC.

- NOTES:**
1. ALL DIMENSIONS SUBJECT TO ALLOWABLE TOLERANCES
 2. STEP GROOVES ARE 16" ON CENTER AND 2" DIA
 3. #3 REBAR REINFORCING ROD

DRAWN	9/3/2020	PRECAST CONCRETE LLC.		
CLH				
CHECKED		TITLE: 38" VAULT RISER		
QA		PROJECT: PRODUCT DRAWINGS		
MFG		SIZE	DWG NO	REV
APPROVED	2/9/2021	B	55-0010	-
CLH/EK		SCALE	SHEET 1 OF 1	